

Accuphase

Class-A
STEREO POWER AMPLIFIER

A-48S

- Class A driven output stage with 6-parallel push-pull power MOS-FETs
- Large linear output of 50 W / 8 ohms, 100 W / 4 ohms, 200 W / 2 ohms, 400 W / 1 ohm
- Instrumentation amplifier
- Current feedback amplification topology
- Balanced remote sensing
- MCS+ circuit
- High damping factor of 1,000
- Speaker output protection
- Highly responsive large-scale power meters
- Support for bi-amping and bridged mode connections





Class A power amplifier building upon state-of-the-art Accuphase designs

The A-48S incorporates state-of-the-art technologies to create a Class A power amplifier that delivers superb performance. Benefitting from years of ideal designs of high-performance units, the A-48S utilizes 6-parallel pull-push power MOS-FETs and boasts an output of 50 W into 8 ohms, 100 W into 4 ohms, 200 W into 2 ohms, and 400 W into 1 ohm at the same size as conventional models. The noise level has also been further reduced by 6%, while providing a damping factor of 1,000. The A-48S will bring the best out of any speaker, enabling you to enjoy unparalleled sound quality and expansiveness.

Groundbreaking technology

The A-48S employs sophisticated circuitry and carefully selected materials to create a power amplifier with perfectly honed expressiveness.

Ample output power

The Class A driven 6-parallel push-pull power MOS-FETs in the output stage produce a linear output power of 50 W into 8 ohms, 100 W into 4 ohms, 200 W into 2 ohms, and 400 W into 1 ohm.

Excellent noise suppression performance

Ideal gain distribution and other sophisticated techniques improve noise level suppression by 6% over conventional models.

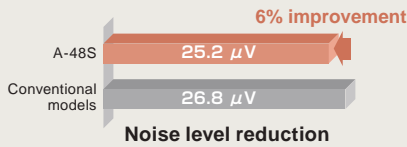

High damping factor

With a damping factor of 1,000, the speakers can be driven with full control over the counter-electromotive forces to get the most out of your speakers.

Ideal gain distribution

Allocating a high gain (12.6x) in the signal input section with its superb noise suppression rating drastically reduces output noise.

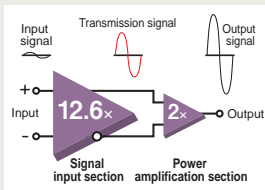

Balanced remote sensing

Balanced remote sensing improves the damping factor by feeding back the GND at the same time as the signal output from the speaker terminals.

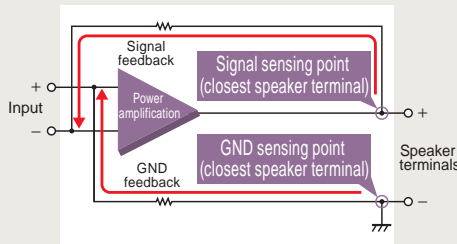

Instrumentation amplifier

With balanced circuits in the signal input section, the amplification stage is comprised entirely of an instrumentation amplifier principle that equalizes input impedance on the + and - sides for excellent external noise suppression while providing optimal circuitry for a high-end audio amplifier.

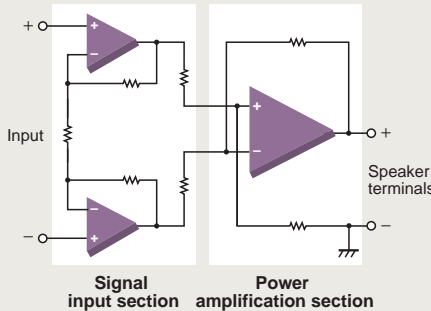

MCS+ circuit

By placing the voltage amplification stage in a two-parallel circuit layout, the MCS+ (Multiple Circuit Summing-up) circuit theoretically lowers the noise floor by about 30%.

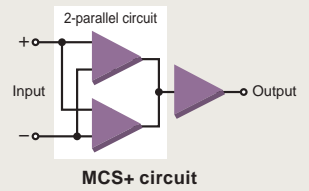

2-parallel circuit layout of MCS+ principle

Current feedback amplification topology

The current feedback amplification circuit offers exceptional performance in the high range with almost no impact on the frequency characteristics even when gain is switched, resulting in natural and dynamic driving of the speakers.

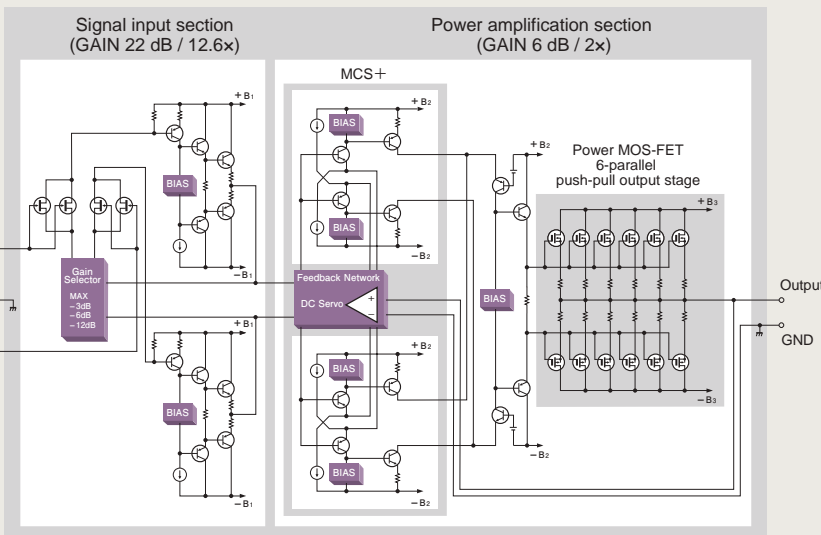
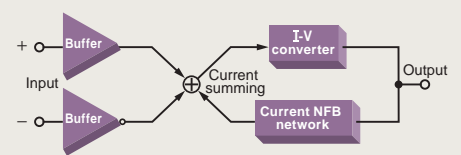

Circuit diagram

Protection circuit section Signal input section



L ch power amplification section Toroidal transformer R ch power amplification section

Advanced features

- Class A driven 6-parallel push-pull MOS-FET output stage
- Large linear output of 50 W / 8 ohms, 100 W / 4 ohms, 200 W / 2 ohms, 400 W / 1 ohm
- Instrumentation amplifier
- Current feedback amplification topology
- Balanced remote sensing
- MCS+ circuitry
- High damping factor of 1,000
- Meter display selector ①
- LINE / BALANCED input switching ②
- 4-step gain control ③
- Polarity switching of balanced input connectors ④
- Bi-amping connection and bridged connection switching ... ⑤
- Ideal gain distribution in the signal input section ⑥
- Speaker output protection circuit guards against short-circuiting ⑦
- Large speaker terminals connected directly to protection circuitry ⑧
- Highly reliable MOS-FET switches with no mechanical connections ⑨
- Large, high-efficiency toroidal transformer ⑩
- High capacity 68,000 μF filtering capacitors ⑪
- Aluminum hairline finish top plate ⑫
- High-carbon cast iron insulator feet with superior damping characteristics ⑬
- Large, high-sensitivity power meters ranging from -50 dB ... ⑭
- Power amplification section with a large heat sink ⑮

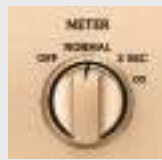

① Meter display selector



② Input selector button ③ Gain selector



④ Balanced input polarity selector



⑤ Operation mode selector

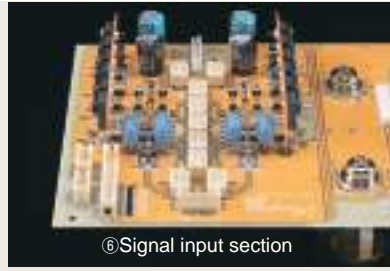

⑥ Signal input section

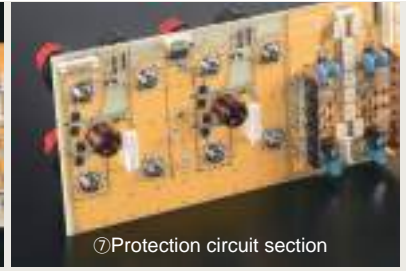

⑦ Protection circuit section



⑧ Speaker terminals



⑨ MOS-FET switches



⑩ Toroidal transformer

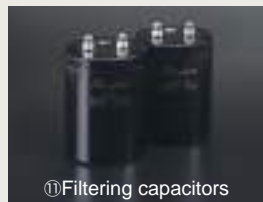

⑪ Filtering capacitors



⑫ Top plate



⑬ Insulator feet



⑭ Power meters



⑮ Power amplification section



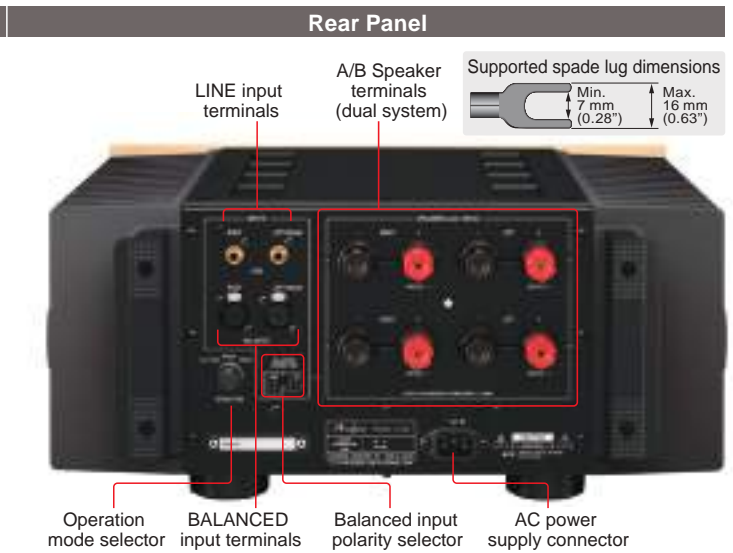
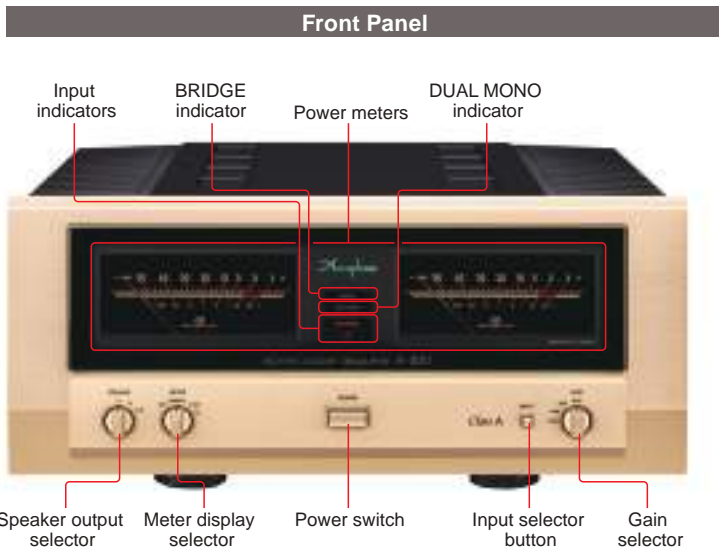
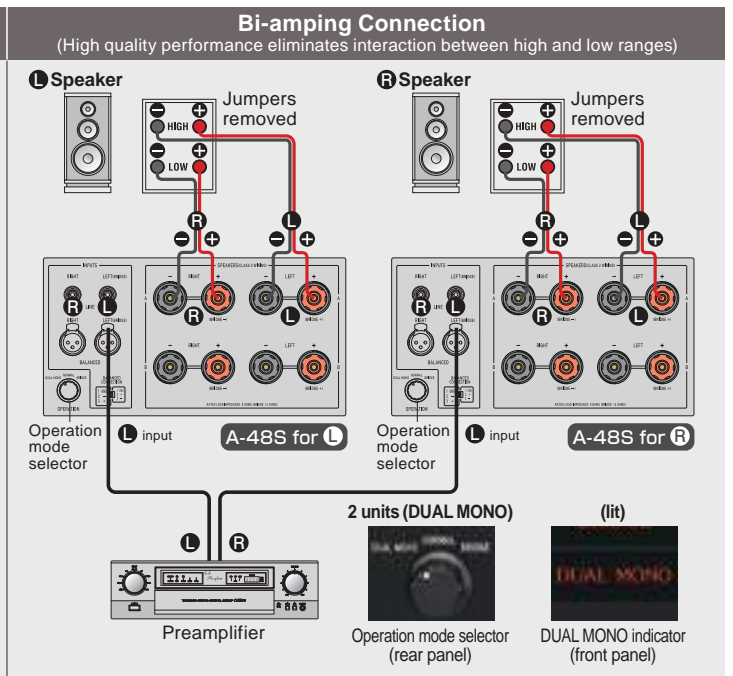
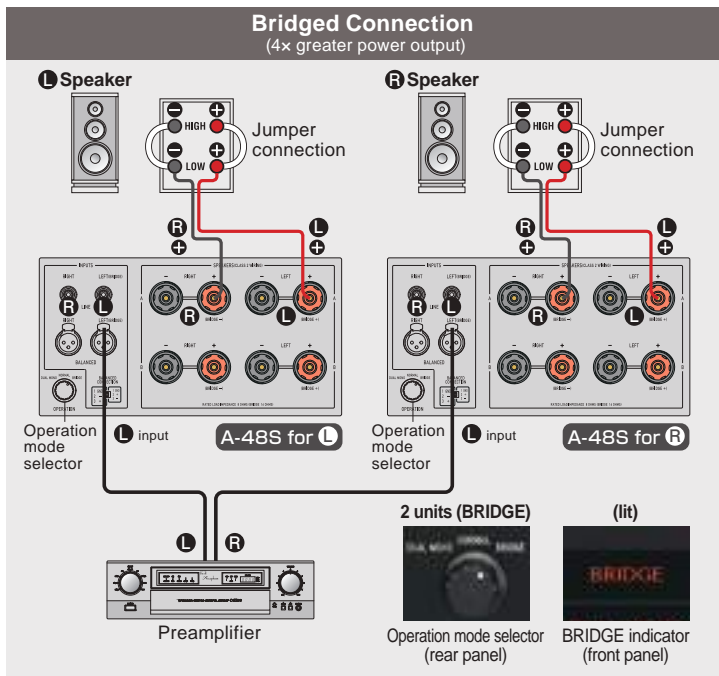

A-48S Guaranteed Specifications

Rated Output (20 – 20,000 Hz)	Load			
	8 ohms	4 ohms	2 ohms	1 ohm
Normal / Bi-amping connection	50 W	100 W*	200 W*	400 W*
	Bridged connection			
Total Harmonic Distortion (20 – 20,000 Hz, at rated output)	2 ohms		0.05%	
	Normal / Bi-amping connection		4 to 16 ohms	0.03%
Bridged connection		4 to 16 ohms	0.05%	
Intermodulation Distortion	0.01%			
Frequency Response	At rated output			
	20 – 20,000 Hz (+0, –0.2 dB)			
Damping Factor	At 1 W output			
	0.5 – 160,000 Hz (+0, –3 dB)			
Input Impedance	Normal / Bi-amping connection			
Input Sensitivity	BALANCED / LINE input		40 kilohms / 20 kilohms	
	Output		At rated output	At 1 W output
	Normal / Bi-amping connection		0.80 V	0.11 V
Bridged connection		1.59 V	0.11 V	
Signal-to-Noise Ratio (A-weighted, input shorted)	GAIN switch at MAX / –12 dB		118 dB / 123 dB	

*: Limited to music signals

Gain	Gain switch	MAX	–3 dB	–6 dB	–12 dB
	Gain	28 dB	25 dB	22 dB	16 dB
Power Meters	Format	Logarithmic scale, with illumination Off switch			
	Display range	–∞ to +3 dB			
	Hold time	0 sec. / 3 sec. / ∞ switchable			
Power requirements	120/220/230 V AC, 50/60 Hz (Voltage as indicated on rear panel)				
Power Consumption	Idle	200 W			
	In accordance with IEC62368-1	220 W			
	Stand-by	0.3 W			
Maximum Dimensions	Width 465 mm (18.3") x Height 211 mm (8.3") x Depth 464 mm (18.3")				
Mass	Net	34.8 kg (76.8 lbs)			
	In shipping carton	41 kg (91 lbs)			

● The measurement methods for the Guaranteed Specifications comply with JEITA CP-1301A and IEC 60268-3.

● "Normal connection" indicates standard operation.

Supplied accessories

- AC power cord (2 m (6.5'))

Remarks

- ★ This product is available in versions for 120/220/230 V AC. Make sure that the voltage shown on the rear panel matches the AC line voltage in your area.
- ★ The 230 V version has an Eco Mode that switches power off after 120 minutes of inactivity.
- ★ The shape of the plug of the supplied AC power cord depends on the voltage rating and destination country.



ACCUPHASE LABORATORY, INC.